

APPLICABLE MODELS  
PA-30 & PA-39

*KNOTS 2U, INC.*

GEAR LOBE FAIRING

INSTALLATION MANUAL  
ISSUE DATE 01/18/92

**EAA  
APPROVED**

MAR 20 1992  
157 Mr. ACR-120C  
CHICAGO AIRCRAFT  
CERTIFICATION OFFICE  
CENTRAL REGION

KNOTS 2U, INC.  
709 AIRPORT ROAD  
BURLINGTON, WI 53105  
(262) 763-5100

REVISION PAGE

REV. No.	DATE	PAGE	EFFECT
A	04/15/92	1,2,3,4,6	CHANGED TABLE OF CONTENTS, FAIRING INSTALLATION PROCEDURES AND MAINTENANCE MANUAL.

**F A A  
A P P R O V E D**

JUN 05 1992  
*for PA-30-120C*  
 CHICAGO AIRCRAFT  
 CERTIFICATION OFFICE  
 CENTRAL REGION

TABLE OF CONTENTS

	<u>PAGE</u>
SECTION 1.0 =LEFT GEAR LOBE INSTALLATION=.....	1
1.1 -JACKING THE AIRCRAFT-.....	1
1.2 -CONFIRMING AIRCRAFT THRUST LINE-.....	1
1.3 -PRELIMINARY LOCATION OF LEFT GEAR LOBES-.....	1
1.4 -LOCATING MOUNTING HOLES FOR LEFT GEAR LOBES-.....	1
1.5 -TEMPORARY INSTALLATION OF LEFT GEAR LOBES.....	1
1.6 -CHECKING FLAP OPERATION AND CLEARANCES-.....	2
1.7 -CHECKING GEAR OPERATION AND CLEARANCES-.....	2
1.8 -INSTALLING RUBBER SEAL ON GEAR LOBES-.....	2
1.9 -FINAL SEALING OF GEAR LOBES-.....	2
 SECTION 2.0 =RIGHT GEAR LOBE INSTALLATION=.....	 3
SECTION 3.0 =PAPERWORK=.....	3
SECTION 4.0 =PARTS LIST=.....	3
SECTION 5.0 =DETAIL #1=.....	4
SECTION 6.0 =SUPPLEMENTAL TYPE CERTIFICATE=.....	5
SECTION 7.0 =MAINTENANCE MANUAL=.....	6

F A A  
A P P R O V E D

JUN 05 1992  
SJM ACB-120C  
CHICAGO AIRCRAFT  
CERTIFICATION OFFICE  
CENTRAL REGION

NOTE #1:

IF ADJUSTMENT OR RE-RIGGING OF THE FLAPS IS REQUIRED IT SHOULD BE COMPLETED, ACCORDING TO THE APPROPRIATE PIPER SERVICE MANUAL, PRIOR TO INSTALLATION OF THE GEAR LOBE FAIRINGS. THE REAR FAIRINGS ARE MOUNTED TO THE FLAP SURFACE AND ANY CHANGE IN THE FLAP RIGGING, AFTER THE INSTALLATION COULD MAKE IT NECESSARY TO REPOSITION THE REAR LOBES. IT IS SUGGESTED THAT THE FLAP RIGGING BE VERIFIED BEFORE THE INSTALLATION. ALSO IT IS IMPORTANT TO LIMIT THE DRILLING DEPTH FOR THE RIVNUT INSTALLATION TO THE REQUIRED DEPTH AND NOT TO DRILL UNNECESSARILY DEEP.

SECTION 1.0 =LEFT GEAR LOBE INSTALLATION=1.1 -JACKING AIRCRAFT-

AIRCRAFT SHOULD BE PLACED ON JACKS WITH TAIL SECURED BY TAIL STAND TO ENABLE A RETRACTION TEST TO ASSURE PROPER TIRE CLEARANCE DURING RETRACTION CYCLE. FURTHER, THE AIRCRAFT SHOULD BE LEVEL FOR FLAP RIGGING VERIFICATION.

1.2 -CONFIRMING AIRCRAFT THRUST LINE-

REFERRING TO DETAIL #1 FIGURE #2 USE A STRAIGHT EDGE TO LOCATE AND MARK THE AIRCRAFT CENTERLINE ON THE SKIN AT THE LEFT WHEEL WELL LOCATION. THE RIVET COUNT IS ACCORDING TO PIPER DRAWINGS AND IF THERE IS ANY DEVIATION IT IS IMPORTANT TO FOLLOW THE ACTUAL THRUSTLINE WHICH CAN BE DETERMINED BY CAREFUL MEASUREMENT FROM THE FUSELAGE CENTERLINE.

1.3 -PRELIMINARY LOCATION OF LEFT GEAR LOBES-

TAPE THE LEFT GEAR LOBES P/N's 30LOBLF AND 30LOBLR TOGETHER USING MASKING TAPE, WITH GUIDE PINS HOLDING THEM IN PROPER MATING POSITION (THE THICK EDGE INBOARD). REFERRING TO DETAIL #1 FIGURE #1 AND USING THE MARKS AT FRONT EDGE OF FRONT LOBE AND THE REAR EDGE OF THE REAR LOBE, ALIGN FAIRINGS WITH THE THRUST LINE MARK, WITH THE TOP LEADING EDGE EVEN WITH TRAILING EDGE OF WHEEL WELL OPENING. THE LOWER LEADING EDGE WILL BE FORWARD OF THE TOP EDGE WHEN FAIRING IS PROPERLY POSITIONED. TAPE FAIRING FIRMLY IN PLACE AND OBSERVE ALIGNMENT OF THE FAIRING WITH THE TIRE AND THE THRUSTLINE OF THE AIRCRAFT AND CONFIRM THAT THE POSITIONING IS PROPER. BEFORE PROCEEDING FURTHER, THE LANDING GEAR SHOULD BE CYCLED (SEE SECTION 1.6) TO ASSURE THAT THE FAIRING CLEARANCE FROM ANY PART OF THE TIRE IS AT LEAST 1/2".

1.4 -LOCATING MOUNTING HOLES FOR LEFT GEAR LOBES-

USING A PUNCH OR AWL MARK THE HOLE LOCATIONS THROUGH THE COUNTERSUNK POSITIONS ON THE FAIRINGS. REMOVE THE FAIRINGS AND USING A #1 DRILL, DRILL HOLES IN THE SKIN AT THE MARKED LOCATIONS. IF ANY OF THE HOLES WILL FALL ON AN EXISTING RIVET OR SCREW, THE HOLE MUST BE RELOCATED SLIGHTLY ON BOTH THE AIRCRAFT AND THE FAIRING AND THE EXISTING HOLE ON THE FAIRING MUST BE SEALED, USING BONDO. INSTALL 7 P/N AK8-75 RIVNUTS AT THE HOLE LOCATIONS.

1.5 -TEMPORARY INSTALLATION OF LEFT GEAR LOBES-

REFERRING TO DETAIL #1 FIGURES #3 & #4 SECURE P/N 30LOBLF IN PLACE USING 1 P/N AN507-832-R18 SCREW AT THE OUTBOARD RIVNUT, 1 P/N AN507-832-R28 SCREW AT THE CENTER RIVNUT AND 1 P/N AN507-832-R28 AT THE INBOARD RIVNUT. SECURE P/N 30LOBLR IN PLACE USING 1 P/N AN507-832-R18 SCREW AT FRONT OUTBOARD RIVNUT, 1 P/N AN507-832-R18 SCREW AT THE REAR INBOARD RIVNUT, 1 P/N AN507-832-R14 SCREW AT REAR OUTBOARD RIVNUT & 1 P/N AN507-832-R24 SCREW AT THE FRONT INBOARD RIVNUT.

F. A A

PAGE -1-

A P P R O V E D

JUN 05 1992

S/PA ACE-170c  
UNIFORM AIRCRAFTCERTIFICATION OFFICE  
CENTRAL REGION

1.6 -CHECKING FLAP OPERATION AND CLEARANCES-

WITH BOTH LEFT FAIRINGS FIRMLY ATTACHED, BUT WITH RUBBER SEAL NOT INSTALLED, RUN FLAP CAREFULLY UP AND DOWN TO FULL TRAVEL WHILE SOMEONE OBSERVES THE OPERATION TO CONFIRM THAT THE LOBES ARE PROPERLY SEATING INTO EACH OTHER AND THAT THEY DO NOT INTERFERE WITH FLAP OPERATION. IF THE GUIDE PINS TEND TO BIND DURING FLAP OPERATION THEY MAY BE TRIMMED OR REMOVED.

1.7 -CHECKING GEAR OPERATION AND CLEARANCES-

WITH MASTER SWITCH OFF PLACE GEAR SWITCH IN UP POSITION AND USE THE MASTER SWITCH TO TOGGLE THE GEAR UP SLOWLY. HAVE SOMEONE CHECK THE TIRE CLEARANCES AS THE GEAR RETRACTS. THE MINIMUM RECOMMENDED CLEARANCE FROM THE FRONT EDGE OF THE LOBE TO ANY PART OF THE TIRE IS 1/2". (AN APU POWER SUPPLY IS RECOMMENDED FOR THIS OPERATION). IF THE CLEARANCE IS LESS THAN 1/2" THE FAIRING MUST BE LOOSENED AND MOVED SLIGHTLY AFT. THAT WILL NOT BE LIKELY, BUT, IF REQUIRED, WILL BEST BE ACCOMPLISHED BY ELONGATING THE HOLES IN THE FAIRING SLIGHTLY. AFTER SATISFACTORILY CHECKING GEAR OPERATION LOWER GEAR FULLY, OBSERVING PROPER GEAR LIGHT INDICATIONS.

1.8 -INSTALLING RUBBER SEAL ON GEAR LOBES-

AT THIS POINT IT MAY BE DESIRABLE TO PAINT THE FAIRINGS BEFORE INSTALLING THE RUBBER SEAL. SEE DETAIL #1 FIGURE #4. THE SEAL P/N 189-715 SHOULD BE INSTALLED FLUSH WITH THE FORWARD AND SIDE EDGES AND AT THE POINT WHERE THE LOBE FITS AGAINST THE TRAILING EDGE OF THE WING SKIN. SIMILARLY, THE RUBBER SHOULD BE INSTALLED ON THE REAR LOBE SO THERE ARE NO EDGES WHICH ALLOW AIR OR MOISTURE LEAKAGE. ALSO, LAY A STRIP OF RUBBER 1/2" IN FRONT AND 1/2" AFT OF EACH ROW OF SCREW HOLES TO ABSORB THE PRESSURES OF TIGHTENING THE LOBE DOWN. REINSTALL THE GEAR LOBES AND RECHECK THE FLAP OPERATION. IF THE SURFACES OF THE LOBES DO NOT MATE PROPERLY WHEN THE LOBES ARE TIGHTENED YOU MAY SHIM ONE OR THE OTHER WITH EXTRA RUBBER TO CORRECT THE MISALIGNMENT. WHEN THE LOBES ARE SECURELY FASTENED THE MATING LINE OF THE FRONT AND REAR LOBES SHOULD BE AS FLUSH AS POSSIBLE. IN NO CASE SHOULD THE LEADING EDGE OF THE REAR LOBE HANG BELOW THE TRAILING EDGE OF THE FRONT LOBE! PRIOR TO FINAL INSTALLATION OF THE FAIRINGS THE FLAT UPPER SURFACE SHOULD BE CLEANED USING ALCOHOL OR MEK AND THE SURFACE ROUGHED UP SLIGHTLY WITH SANDPAPER. SEVERAL BEADS OF SILICON SHOULD BE APPLIED TO THE SKIN WHERE THE LOBE WILL CONTACT IT. AFTER INSTALLING ALL SCREWS AND CONFIRMING ALL FACETS OF ALIGNMENT AND CLEARANCE REMOVE THE SCREWS INDIVIDUALLY AND APPLY A DROP OF LOCTITE ADHESIVE TO THE FIRST 2 OR 3 SCREW THREADS AND REINSTALL TIGHTLY. THIS SHOULD BE DONE ONE SCREW AT A TIME TO RETAIN THE PROPER POSITIONING OF THE LOBES.

1.9 -FINAL SEALING OF GEAR LOBES-

AFTER LOBES ARE INSTALLED IT IS SUGGESTED THAT A BEAD OF RTV BE INSTALLED AT THE SCREW LOCATIONS AND AROUND THE LOBE EDGES TO GIVE A POSITIVE SEAL AND TO ENHANCE THE APPEARANCE AND AERODYNAMICS. THIS IS BEST DONE WITH THE PART TO BE SEALED MASKED OFF AND AFTER THE SEALANT IS APPLIED IT CAN BE SKIVED OFF, USING A FINGER DIPPED IN ALCOHOL, TO PRODUCE A CLEAN JOINT.

E A A  
A P P R O V E D

JUN 05 1992  
S/M ACB-120C  
CHICAGO AIRCRAFT  
CERTIFICATION OFFICE  
CENTRAL REGION

SECTION 2.0 =RIGHT GEAR LOBE INSTALLATION=

REPEAT STEPS 1.2 THROUGH STEP 1.9 ON RIGHT SIDE.

SECTION 3.0 =PAPERWORK=

PERFORM PAPERWORK (337 AND LOG BOOK ENTRIES). PLACE SUPPLEMENTAL TYPE CERTIFICATE AND KNOTS 2U, INC. MAINTENANCE MANUAL WITH LOG BOOKS.

GEAR LOBE FAIRINGS AND HARDWARE WEIGHT= 2.6 LBS.

GEAR LOBE FAIRINGS AND HARDWARE ARM = 140.00 INCHES

SECTION 4.0 =PARTS LIST=

<u>PART NUMBER</u>	<u>NO. REQ</u>	<u>DESCRIPTION</u>
30LOBLF	1	GEAR LOBE LEFT FRONT
30LOBLR	1	GEAR LOBE LEFT REAR
30LOBRF	1	GEAR LOBE RIGHT FRONT
30LOBRR	1	GEAR LOBE RIGHT REAR
AK8-75	14	RIVNUT
AN507-832-R14	2	SCREW
AN507-832-R18	6	SCREW
AN507-832-R24	2	SCREW
AN507-832-R28	4	SCREW
189-715	35'	PIPER RUBBER SEAL
222-05	.05ML	LOCTITE ADHESIVE

**E A A  
A P P R O V E D**

JUN 05 1992  
*S/M RCR-120C*  
 CHICAGO AIRCRAFT  
 CERTIFICATION OFFICE  
 CENTRAL REGION

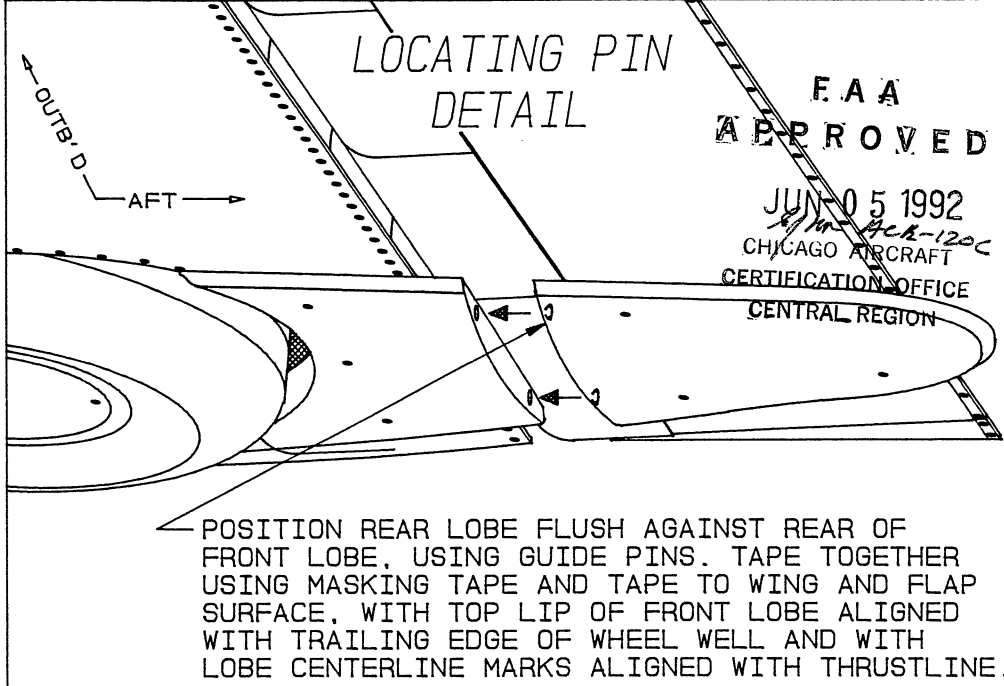

FIGURE #1

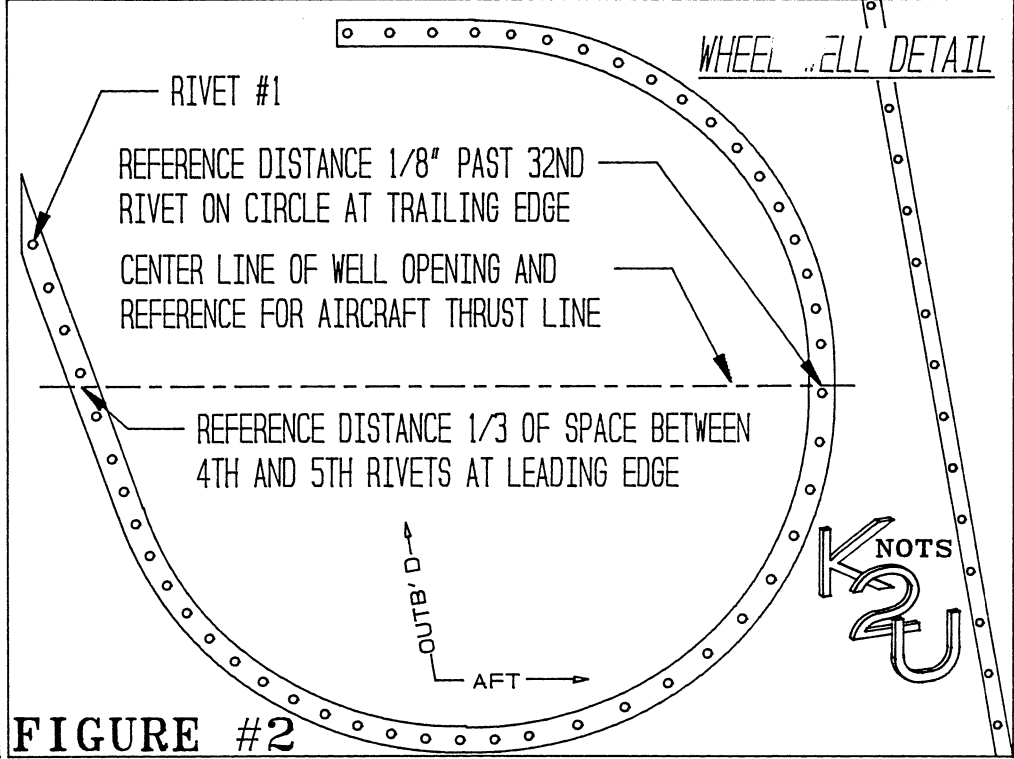

FIGURE #2

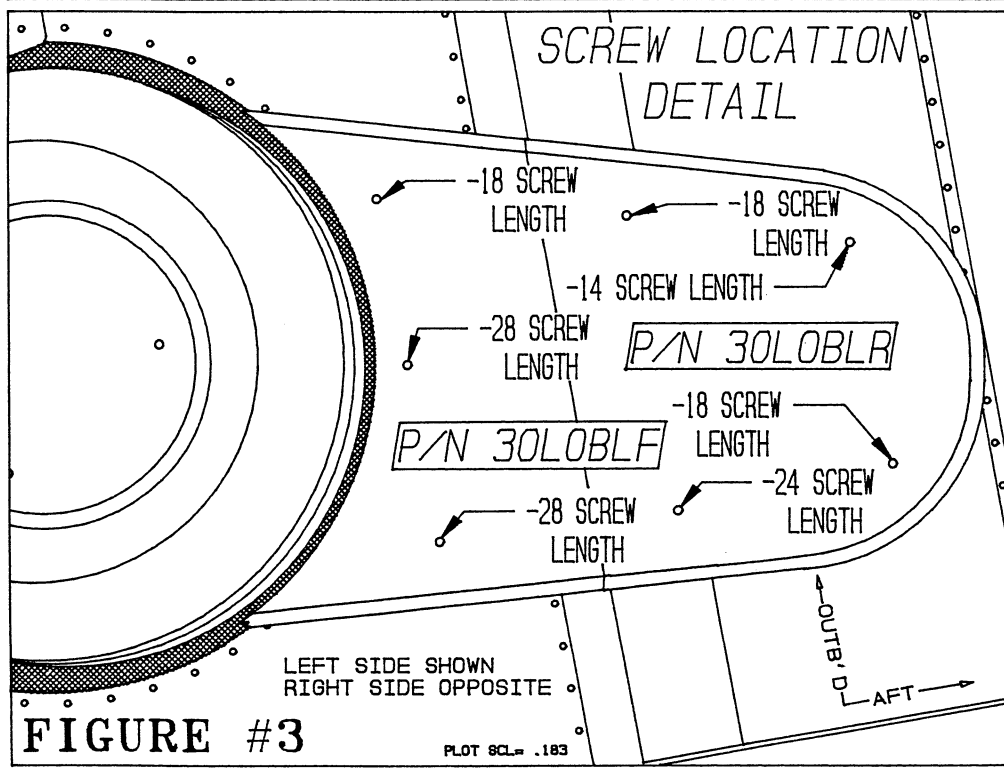
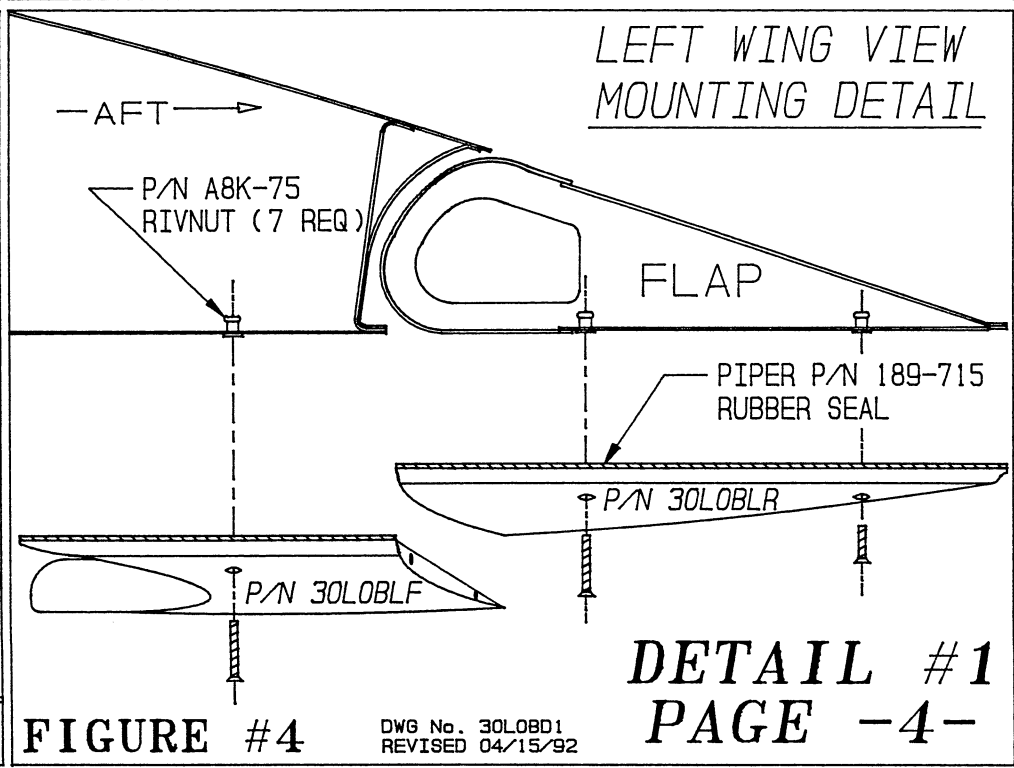

FIGURE #3



=SECTION 7.0 MAINTENANCE MANUAL=KNOTS 2U, INC.

PIPER PA-30 &amp; PA-39

GEAR LOBE FAIRINGS

PART A. INSPECTION

1. During annual or 100 hour inspections, inspect Gear Lobe attachment hardware for excessive wear or looseness.

PART B. MAINTENANCE

1. There are no special tools required to maintain the Gear Lobes. Any tools needed are basic hand tools.
2. If the Gear Lobe attachment hardware is found to be excessively worn or loose during the 100 hour/annual inspection, it should be replaced.
3. If the tires are replaced, after the Gear Lobe Fairing installation, it is important to install tires which are at least as wide as the tires which were on the aircraft at the time of installation. If a narrower tire is installed it could change the performance by allowing the fairing to hang below the tire, creating drag.

PART C. CRACKING OR DEFECTS

1. If a crack is found on a Gear Lobe, stop drill the crack and fill it with silicon and smooth the surface.
2. If any crack exceeds 1 inch in length; or, if a crack runs from an attachment hole to the outer edge of the Gear Lobe, remove the part and repair the crack according to FAR 43.13-1A Acceptable Methods, Techniques, and Practices - Aircraft Inspection and Repair, Chapter 2.

F A A  
A P P R O V E D

JUN 05 1992  
S. J. W. H. C. - 1202  
CHICAGO AIRCRAFT  
CERTIFICATION OFFICE  
CENTRAL REGION