

APPLICABLE MODELS
PA-30 & PA-39

KNOTS 2U, INC.

WINDSHIELD "COWLER" FAIRING

INSTALLATION MANUAL
ISSUE DATE 11/11/92

FAA
APPROVED

DEC 16 1992
John ACF-120
CHICAGO AIRCRAFT
CERTIFICATION OFFICE
CENTRAL REGION

Knots 2U, Ltd.
709 Airport Road
Burlington, WI 53105
(262) 763-5100

REVISION PAGE

REV. No.	DATE	PAGE	EFFECT
----------	------	------	--------

F A A
A P P R O V E D

DEC 16 1992
SAW ACE-1200
CHICAGO AIRCRAFT
CERTIFICATION OFFICE
CENTRAL REGION

TABLE OF CONTENTS

	<u>PAGE</u>
SECTION 1.0 WINDSHIELD "COWLER" FAIRING INSTALLATION	1
1.1 -FINDING CENTERLINE OF COWL-.....	1
1.2 -PRELIMINARY FITTING OF FAIRING-.....	1
1.3 -LOCATING AND DRILLING MOUNTING HOLES-.....	1
1.4 -INSTALLING RUBBER SEAL ON FAIRING-.....	1
1.5 -APPLYING RTV SILICONE-.....	1
1.6 -FINAL INSTALLATION PROCEDURES-.....	2
SECTION 2.0 PAPERWORK	2
SECTION 3.0 PARTS LIST	2
SECTION 4.0 DETAIL #1	3
SECTION 5.0 SUPPLEMENTAL TYPE CERTIFICATE	4
SECTION 6.0 MAINTENANCE MANUAL	5

F A A
 APPROVED

DEC 16 1992
 JTW/HCL/1200
 CHICAGO AIRCRAFT
 CERTIFICATION OFFICE
 CENTRAL REGION

SECTION 1.0 WINDSHIELD "COWLER" FAIRING INSTALLATION1.1 FINDING CENTERLINE OF COWL

REFERRING TO DETAIL #1 FIND THE TWO ROUNDHEAD RIVETS LOCATED AT THE CENTER OF THE COWL JUST AFT OF THE COWL COVER. THE CENTER OF THE SPACE BETWEEN THEM IS THE CENTER OF THE COWL AND SHOULD BE MARKED ON THE COWL COVER.

1.2 PRELIMINARY FITTING OF FAIRING

REFERRING TO DETAIL #1 PLACE FAIRING IN POSITION WITH THE AFT LIP RESTING ON THE EXISTING WINDSHIELD COLLAR, WITH THE LEADING EDGE CENTERED, USING THE CENTERLINES ON THE COWL AND THE FAIRING. IT MAY BE NECESSARY TO GRIND A LITTLE SPOT ON THE FAIRING AT EACH OF THE TWO CENTER RIVETS TO MAKE THE FAIRING SET MORE FLUSH WITH THE EXISTING COWL. IF THE FAIRING OVERLAPS THE COWL COVER IT MUST BE TRIMMED BACK TO SET BEHIND THE COWL COVER.

1.3 LOCATING AND DRILLING MOUNTING HOLES

TAPE THE FAIRING FIRMLY IN POSITION AND REFERRING TO DETAIL #1 DRILL A #30 PILOT HOLE AT THE FRONT HOLE LOCATION THROUGH THE FAIRING AND THE COWL SKIN. OBSERVE THE .5 INCH MINIMUM EDGE DISTANCE AND DO NOT DRILL ANY DEEPER THAN NECESSARY! THE AFT HOLES ARE OPTIONAL SINCE THE RTV SILICONE HOLDS THE FAIRING IN PLACE QUITE WELL. IF YOU CHOOSE TO INSTALL THE AFT SCREW, DRILL A #30 PILOT HOLE AT EACH SIDE OF FAIRING AT THE AFT LOCATIONS. REMOVE THE FAIRING AND ENLARGE THE PILOT HOLES IN THE SKIN TO #2 DRILL SIZE AND THE PILOT HOLES IN THE FAIRING TO #20 DRILL SIZE. COUNTERSINK THE FAIRING HOLES USING A 100 DEGREE COUNTERSINK. INSTALL ONE P/N A8K-75 RIVNUT AT EACH COWL HOLE LOCATION.

1.4 INSTALLING RUBBER SEAL ON FAIRING

REFERRING TO DETAIL #1 INSTALL PIPER SEAL P/N 189-715 AROUND THE INSIDE OF THE TRAILING EDGE OF THE FAIRING, WHERE IT MEETS THE LEADING EDGE OF THE WINDSHIELD, FLUSH WITH THE EDGE OF THE FAIRING.

1.5 APPLYING RTV SILICONE

THE FAIRING HAS BEEN CLEANED PRIOR TO SHIPMENT, HOWEVER THE COWL AREA SHOULD BE THOROUGHLY CLEANED PRIOR TO INSTALLATION, USING PREP-SOL SOLVENT, OR EQUIVALENT. APPLY RTV SILICON TO THE BACKSIDE OF THE FAIRING ACCORDING TO DETAIL #1. INSTALL FAIRING AND SECURE USING P/N AN507-832-R8 SCREWS AND P/N 3135-017-24A WASHERS AT EACH HOLE LOCATION. IT IS IMPORTANT TO POSITION THE FAIRING PROPERLY BEFORE THE SILICONE SETS UP. THE EDGES SHOULD BE TAPED SECURELY IN PLACE AND ANY EDGES WHICH BULGE AWAY FROM THE SKIN SHOULD BE WEIGHTED DOWN OR BRACED IN PLACE WHILE THE RTV SILICONE SETS UP. CLEAN AREAS WHERE SILICONE OVERLAPS, USING ALCOHOL.

F A A
A P P R O V E D

PAGE -1-

DEC 16 1992
D/M ACE-1200
CHICAGO AIRCRAFT
CERTIFICATION OFFICE
CENTRAL REGION

1.6 -FINAL INSTALLATION PROCEDURES-

AFTER SILICONE CURES AND BRACING AND/OR TAPE IS REMOVED THE EDGES OF THE FAIRING SHOULD BE MASKED TO ALLOW A SMALL BEAD OF SILICONE TO BE APPLIED TO THE ENTIRE EDGE FOR MOISTURE PROTECTION AND BEST APPEARANCE. SEE DETAIL #1.

SECTION 2.0 =PAPERWORK=

PERFORM PAPERWORK (337 AND LOG BOOK ENTRIES). PLACE SUPPLEMENTAL TYPE CERTIFICATE AND KNOTS 2U, INC. MAINTENANCE MANUAL WITH LOG BOOKS.

WINDSHIELD "COWLER" AND HARDWARE WEIGHT= 1.0 LBS.
FAIRINGS AND HARDWARE ARM= 54.75 INCHES

SECTION 3.0 =PARTS LIST=

<u>PART NUMBER</u>	<u>NO. REQ</u>	<u>DESCRIPTION</u>
30WS	1	WINDSHIELD "COWLER" FAIRING
AN507-832-R8	4*	SCREW
3135-017-24A	4*	WASHER
189-715	6'	PIPER WINDOW SEAL
A8K-75	4*	RIVNUT

*TWO ARE OPTIONAL, SEE SECTION 1.3

E A A
A P P R O V E D

DEC 16 1992
Mr. A.C.F. - 1200
CHICAGO AIRCRAFT
CERTIFICATION OFFICE
CENTRAL REGION

PIPER PA-24, PA-30/39 WINDSHIELD "COWLER" INSTALLATION

NOTES
K2U

DASHED LINES REPRESENT
TYPICAL PATTERN FOR
RTV SILICONE BEAD

REFERENCE RIVETS
FOR CENTERING

CENTERLINE
MARK

RTV SILICONE
SEALING EDGE

SECTION A-A

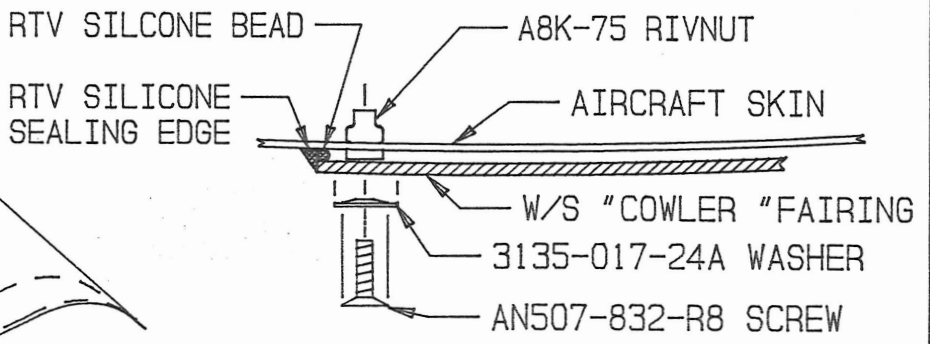

SECTION B-B

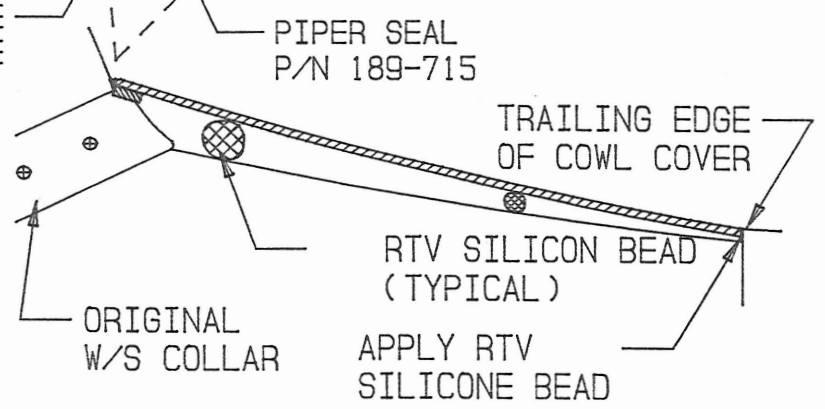

OPTIONAL SCREW

MOUNTING SCREW
MIN. EDGE DIS.
.5 (TYPICAL)

DASHED LINES REPRESENT
TYPICAL PATTERN FOR
PIPER SEAL P/N 189-715

DWG. No. 30WSCOW
11/11/92 PLT SCL .085

CHICAGO AIRCRAFT
 CERTIFICATION OFFICE
 CENTRAL REGION
 DEC 16 1992
 APPROVED
 FAA

=SECTION 6.0 MAINTENANCE MANUAL=KNOTS 2U, INC.

PIPER PA-30 & PA-39

WINDSHIELD "COWLER" FAIRING

PART A. INSPECTION

1. During annual or 100 hour inspections, inspect fairing attachment hardware for excessive wear or looseness.

PART B. MAINTENANCE

1. There are no special tools required to maintain the fairing. Any tools needed are basic hand tools.
2. If the fairing attachment hardware is found to be excessively worn or loose during the 100 hour/annual inspection, it should be replaced.

PART C. CRACKING OR DEFECTS

1. If a small crack is found on the fairing, stop drill the crack and fill it with silicon and smooth the surface.
2. If any crack exceeds 1 inch in length; or, if a crack runs from an attachment hole to the outer edge of the fairing, repair the crack according to FAR 43.13-1A Acceptable Methods, Techniques, and Practices Aircraft Inspection and Repair, Chapter 2.

EAA
APPROVEDDEC 16 1992
15/16-ACE-1200
CHICAGO AIRCRAFT
CERTIFICATION OFFICE
CENTRAL REGION