

## ADS-C1401 CESSNA CABIN DOOR SEAL INSTALLATION INSTRUCTIONS.

### 1. REMOVAL OF OLD SEALS

- a. Using a small putty knife, gasket scraper or similar tool, pry a section of the seal away from the door until you have a section of the seal large enough to hold onto. A heat gun may be used to assist in removal of the old seal. Apply heat to the underside of the seal as you lift it from the door, continue until entire seal is removed.
- b. After the seal is removed there will still be adhesive residue left on the door. Using a liberal amount of adhesive remover, per the manufacturer's instructions, remove the old adhesive. (PEERCO 321 is specifically designed to remove this type of adhesive and is sold by Knots 2U in a convenient pint size can). **NOTE THAT MOST ADHESIVE REMOVERS ARE FLAMABLE!**
- c. After adhesive is removed, thoroughly clean the surface. Allow it to completely dry before proceeding with the installation of the new seal.

### 2. ADJUSTING THE DOOR

- a. With the old door seal removed, now is a good time to make any adjustments to the door. While sitting in the plane with the door closed, look for areas with an excessive gap. From the outside of the aircraft check for areas where the door is bent, warped or not fitting evenly with the fuselage. If adjustments are necessary, they should be accomplished before installing the new seal.

### 3. INSTALLING NEW SEALS

- a. To install the new seal use either 3M 08001, 3M EC1300L or equivalent adhesive.
- b. Brush an even layer of adhesive to the door perimeter surface as shown on the installation drawing View A-A. Allow the adhesive to completely dry.
- c. Apply adhesive to the *thick edge* of the seal (Reference View A-A) approximately 8 inches at a time. Start the seal installation at the bottom of the door, approximately in the center. Continue working around the door in 8" sections keeping the adhesive on the seal wet so that it does not bond to the door in the wrong position. If the seal is wet enough you will have up to 4 minutes working time before it takes a final set. **DO NOT STRETCH THE SEAL DURING INSTALLATION. ESPECIALLY AROUND THE CORNERS!!**
- d. Trim off the excess seal with a scissors (leave seal approximately 1/8" long) and butt it up to the end of the seal where the installation began.
- e. Using the enclosed pack of seal lube (pure silicone grease), wipe a light film of lube over the entire seal, remove any excess with a dry cloth. To keep your seals looking new for many years re-apply lube annually.
- f. After the adhesive has fully cured you may close the door. Note that the door may initially require more effort to close than you have experienced in the past. This is due to the special rubber compound that will enable the seal to compress and "form fit" to the door and door frame. After sitting in the closed position for a day or two the door will close easily and seal perfectly.

Aircraft Door Seals, Inc. *A Division of Knots 2U, Ltd.*  
709 Airport Road  
Burlington, WI 53105  
(262) 763-5100

RIGHT SIDE CABIN DOOR INSTALLATION (TYP. ALL MODELS)  
(SAME FOR LEFT SIDE)

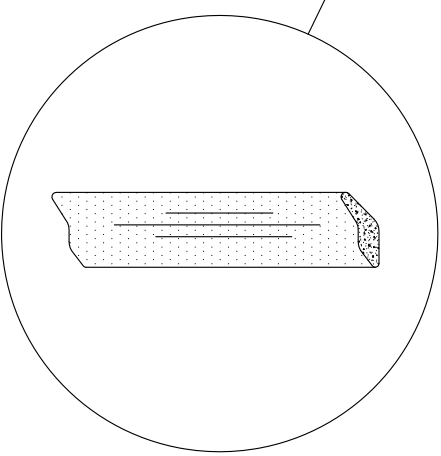
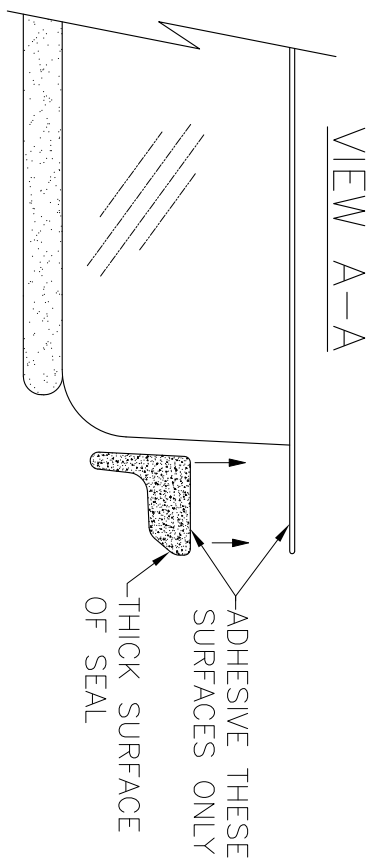
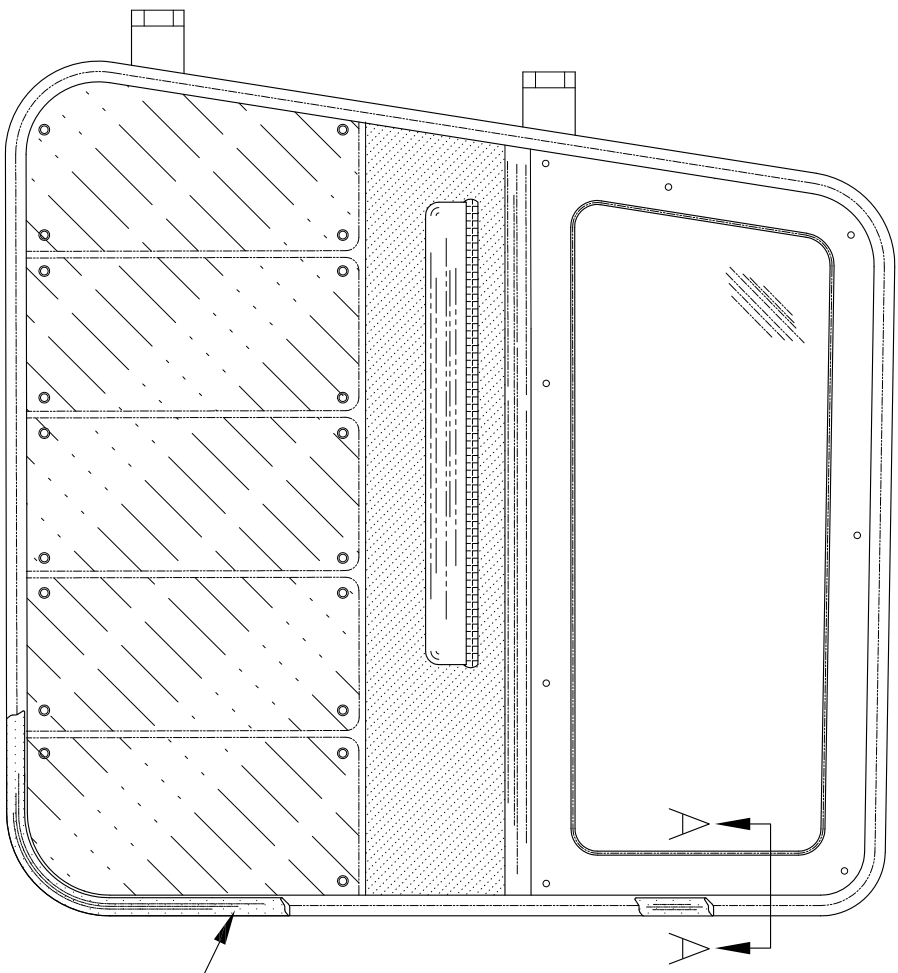

ADS1200-401